

Product data sheet

Characteristics

9070T1500D37

Transformer, Type T, industrial control, 1500 VA, 600 VAC primary / 120/240 VAC secondary, 1 phase, 50/60 Hz, 55 °C rise



Product availability: Non-Stock - Not normally stocked in distribution facility

Price*: 1284.00 USD



Main

Product or component type	Industrial Control Transformer
Rated power in VA	1500 VA
Range of product	T

Complementary

Phase	1 phase
Rated power in VA	1500 VA UL 1500 VA CSA 1500 VA NOM 1000 VA
Temperature rise	115 °C
Electrical connection	Screw clamp terminals
Height	6.17 In (156.72 mm)
Width	7.06 In (179.32 mm)
Depth	5.92 In (150.37 mm)
Product compatibility	FSC2

Environment

Product certifications	UL Listed CSA
NEMA degree of protection	Not rated (open device)
Insulation temperature	356 °F (180 °C)

Ordering and shipping details

Category	16206 - 9070 T (NOT TF) MTO
Discount Schedule	CP8
GTIN	00785901803782
Nbr. of units in pkg.	1
Package weight(Lbs)	34.60 Lb(US) (15.694 kg)
Returnability	No
Country of origin	US

Packing Units

Unit Type of Package 1	PCE
Package 1 Height	11.60 In (29.464 cm)
Package 1 width	11.90 In (30.226 cm)
Package 1 Length	15.00 In (38.1 cm)

Offer Sustainability

Sustainable offer status	Green Premium product
California proposition 65	WARNING: This product can expose you to chemicals including: Phenyl glycidyl ether, which is known to the State of California to cause cancer and birth defects or other reproductive harm. For more information go to www.P65Warnings.ca.gov
REACH Regulation	REACH Declaration
EU RoHS Directive	Compliant EU RoHS Declaration
Mercury free	Yes
RoHS exemption information	Yes
China RoHS Regulation	China RoHS Declaration
Environmental Disclosure	Product Environmental Profile
PVC free	Yes

Contractual warranty

Warranty	10 Years
----------	----------

Approximate Dimensions

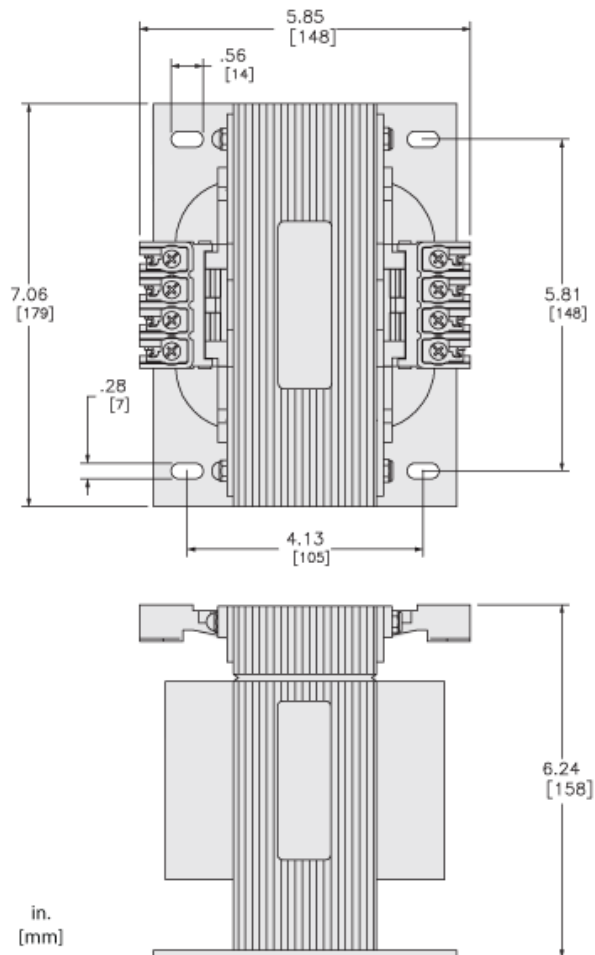

Connections and Wiring Diagrams

Voltage and Connection Options

Voltage Code	Voltages		Connections	
	Primary	Secondary	Primary	Secondary
D33	380/400/415	115/230	380: Connect to H1 and H2 400: Connect to H1 and H3 415: Connect to H1 and H4	115: Connect to X1 and X4 Jumper X1 with X3 Jumper X2 with X4 230: Connect to X1 and X4 Jumper X2 with X3
D37	550/575/600	110/220 115/230 120/240	550 or 575 or 600: Connect to H1 and H2	110 or 115 or 120: Connect to X1 and X4 Jumper X1 with X3 Jumper X2 with X4 220 or 230 or 240: Connect to X1 and X4 Jumper X2 with X3
D60	277	120/240	277: Connect to H1 and H2	120: Connect to X1 and X4 Jumper X1 with X3 Jumper X2 with X4 240: Connect to X1 and X4 Jumper X2 with X3

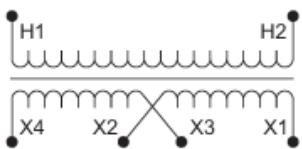
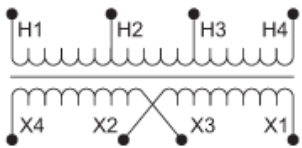

Product Life Status : **Commercialised**